

AGNEUS AGCD840V20 Street Light Controller

Solar Battery Charge Regulator with Night Load controller
User's Manual
READ BEFORE TO INSTALL



General Safety Recommendations



1. Batteries stores a large amount of energy. **Under all circumstances, never short circuit a Battery. We recommend connecting a fuse directly to the positive battery terminal**, adjusted to the maximum intensity of use and without overpass the nominal intensity of AGNEUS Regulator.
2. **Batteries can produce flammable gases.** Avoid making sparks using fire or any naked flame. Be sure that the battery room is ventilated.
3. **Avoid touching or short circuiting wires or terminals.** Use isolated tools, remains always in dry floor and keep your hands dry.
4. **Keep children away** from batteries and the charge regulator.
5. Please, observe the safety recommendations of the battery manufacturer. If you have any doubt, consult your seller or installer.

Intended Use

The charge regulator is designed to be used in a isolated photovoltaic system for a Lead-acid battery with 12V of nominal voltage. Deep charge algorithm is specially optimized for gelificated battery.

Liability Exclusion

The manufacturer shall not be able for damages, especially on the battery, caused by use other than as intended or as mentioned in this manual, or if the recommendations of the battery manufacturer are neglected. The manufacturer shall not be liable if there has been service or repair carried out by any unauthorized person, unusual use, wrong installation or bad system design.

Opening case voids warranty.

General Description



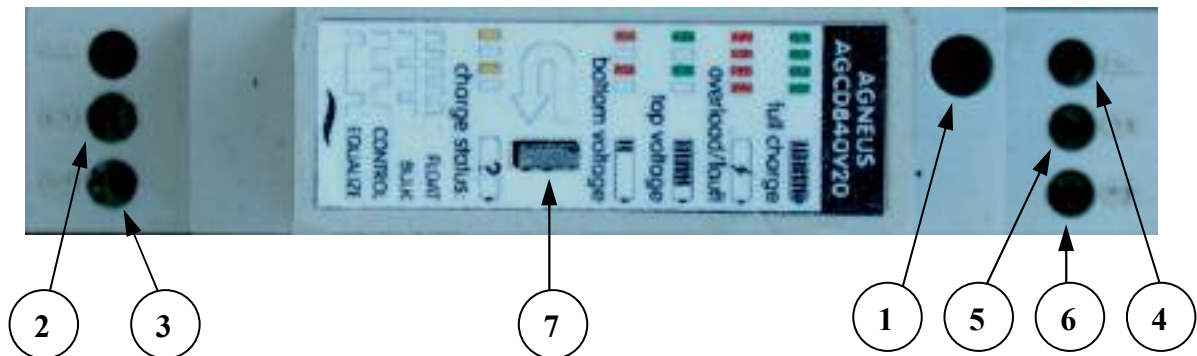

The battery charge regulator AGNEUS AGCD840V20 tracks the Maximum Power Point of the photovoltaic module (*Maximum Power Point Tracking MPPT*), increasing till 30% of the electric energy yields if compares with the traditional market regulators. Moreover, it makes an active control of photovoltaic module and loads, to protect battery from overcharge and extended uses without finishing a deep battery charge or equalization charge.

Street Light Controller option: Lights are automatically started at night during by hourly schedule or full night till sunrise.



1. **Switch on Loads LED indicator**
2. **Positive of Photovoltaic module PV+**
3. **Negative of Photovoltaic module PV-**
4. **Positive of the output for user's loads OUT+**
5. **Positive of battery BAT+**
6. **Negative of battery BAT-**
7. **Battery State LED indicator: alternate 1 minute function charge status / battery condition**

ORANGE blink:
CHARGE STATUS

 FLOAT
 BULK
 CONTROL
 EQUALIZE

Fast GREEN blink:
PWM CHARGE MODE

GREEN blink: Top battery voltage
 RED blink: Bottom battery voltage
 GREEN ON: Battery full charged
 RED ON: Overload / Fault

Installation and connection (see figures 1 and 2)

Protects the regulator from direct sun light and rain and place it in a dry and non flammable surface (the regulator warms up during operation). The distance between the regulator and the battery should be as short as possible, always below 1m length. Use wires of $2,5\text{mm}^2$ of maximum thickness.

Between regulator output OUT+ (4) and loads positive side (12V luminaries, for example), we will insert the switch breaker, as shown in the figure 2. User loads negative side will be connect directly to the battery negative terminal.

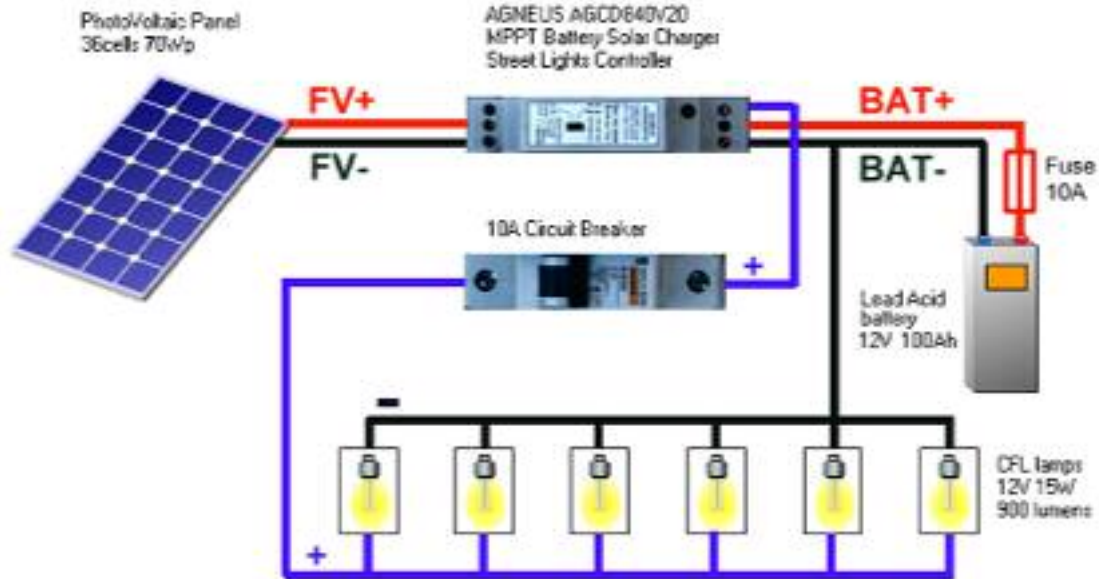

Before begin to install, be sure that battery is not connected!



1. Install the electric enclosure and inserts the regulator and the switch breaker in the DIN RAIL.
2. Connect the regulator output terminal OUT+ (4) at switch breaker nearest terminal. Be sure that the switch lever is at OFF position. Connect the other switch breaker terminal to the positive side of your desired loads to be supplied.
3. **With battery unconnected**, insert the positive wire of battery BAT+ to the regulator terminal (5). After, insert the negative wire BAT- to the regulator terminal (6).
4. Now proceed to make the battery connections. **Attention! If inverts the battery polarity, could be produced irreparable damages over the regulator.**
5. Connect the positive wire of the photovoltaic module PV+ to the regulator terminal (2)
6. Connect the negative wire of the photovoltaic module PV- to the regulator terminal (3)

Components Technical Specifications			
Lead acid Battery		Photovoltaic module	
Nominal Voltage	12V	Peak power	100Wp maximum
Maximum capacity C_{10}	120Ah	V_{OC} (open circuit)	31V maximum
Minimum capacity C_{10}	60Ah	I_{SC} (short circuit)	8A maximum
Technical Specifications - AGNEUS regulator			
Specification	Nominal	Maximum	Minimum
Battery voltage V_{BAT}	12V	15V	10V
Track V_{MPP} PV module	17V	25V	V_{BAT}
Charge current	7A	8,3A	0,01A
Load current	7,5A	10A	0A
Self consumption	2W	3W	0,1W (night)
Temperature	25°C	60°C	-15°C
General data - AGNEUS regulator			
Dimensions & weight width x height x deep	19mm x 93mm x 71mm		100 gr.
Kind of regulation	Maximum Power Point Tracking MPPT		
Deep Charge algorithm	4 estates with active control of charge current		
Battery charge control Voltages	13,5V _{FLOAT}	14,4V _{BULK}	14,5V _{CONTROL} 15V _{EQUALIZE}
Charge cycles interval	Minimum 1 day till a maximum of 30 days		
Load Control	Hourly schedule	Lights ON 4 hours at sunset	1 hour before sunrise
	Full night	Lights ON at sunset	Lights OFF if $V_{BAT} < 11,7V$
	Dimmer light	Lights ON 6 hours at sunset	Dimmer 50% rest of night
Device protections	Low battery	PV module polarity	overcharge
			short circuit
Case protection degree	IP54 AGNEUS regulator		IP23 Street Light C. kit